

Trumpf TruBend 7036 (40 T)



Bend table minimum guidelines chart is for steel (A36) up to a 90° single bend ONLY.
 See below for other bends or alternate materials. Standard radius is equal to material thickness.

MATERIAL THICKNESS	8X THK	STANDARD DIE WIDTH	MINIMUM ENTITY TO BEND	MINIMUM FLANGE LENGTH	LONGEST BEND	MAX DEGREE	K FACTOR MS / SS
(.048)18 ga	0.38	0.384" (10MM)	0.281	0.317	40	35	0.156 / 0.065
(.060)16 ga	0.48	0.384" (10MM)	0.281	0.317	40	35	0.400 / 0.283
(.075)14 ga	0.60	0.472" (12MM)	0.332	0.361	40	35	0.300 / 0.225
(.105)12 ga	0.84	5/8" (16MM)	0.406	0.440	40	35	0.380 / 0.350
(.120)11 ga	0.96	5/8" (16MM)	0.406	0.440	31	35	0.315 / 0.380
(.135)10 ga	1.08	1" (30MM)	0.85	0.875	40	35	0.350 / 0.355*(16mm)
.188 Plate	1.50	1.5" (40MM)	1.17	1.173	24	35	0.415 / 0.328
.250 Plate	2.00	2" (50MM)	1.25	1.375	30.5	35	0.350 / 0.342
.313 Plate	2.50	2" (50MM)	1.25	1.375	17.5	35	0.335 / 0.328
.375 Plate	3.00	3" (70MM)	1.69	1.875	16.5	55	0.362 / 0.3145

5052 AL K factors	
Thickness	K factor
0.0478	0.135
0.063	0.5
0.08	0.41
0.1	0.485
0.125	0.5
0.188	0.415
0.25	0.345
0.313	0.328
0.375	0.3135

86° (90°) dies available	
Size	Length
0.3149" (8mm)	40
0.472" (12mm)	40
5/8" (16mm)	40
1.5" (40mm)	40

Radius punches available	
Size	Length
0.04 R (1mm)	40
0.16 R (4mm)	10
0.375 R	40
0.500 R	40
0.750 R	40
1.000 R	40

Notes:
 Die bed is 40" and 36.7" between columns
 Max interior box ID = 2.625"
 Max flange at upright 16"



Trumpf TruBend 5320 (360 T)



*Bend table minimum guidelines chart is for steel (A36) up to a 90° single bend ONLY.
See below for other bends or alternate materials. Standard radius is equal to material thickness.*

MATERIAL THICKNESS	8X THK	STANDARD DIE WIDTH	MINIMUM ENTITY TO BEND	MINIMUM LANGE LENGTH	LONGEST BEND	MAX DEGREE	K FACTOR MS / SS
(.048)18 ga	0.38	0.384" (10MM)	0.281	0.317	159	35 OR HEM	0.156 / 0.065
(.060)16 ga	0.48	0.384" (10MM)	0.281	0.317	159	35 OR HEM	0.400 / 0.283
(.075)14 ga	0.60	0.472" (12MM)	0.332	0.361	159	35 OR HEM	0.300 / 0.225
(.105)12 ga	0.84	5/8" (16MM)	0.406	0.440	159	35 OR HEM	0.380 / 0.350
(.120)11 ga	0.96	5/8" (16MM)	0.406	0.440	159	35 OR HEM	0.315 / 0.380
(.135)10 ga	1.08	1" (30MM)	0.85	0.875	172	35	0.350 / 0.355*(16mm)
.188 Plate	1.50	1.5" (40MM)	1.17	1.173	172	35	0.415 / 0.328
.250 Plate	2.00	2" (50MM)	1.25	1.375	172	35	0.350 / 0.342
.313 Plate	2.50	2" (50MM)	1.25	1.375	159	35	0.335 / 0.328
.375 Plate	3.00	3" (70MM)	1.69	1.875	159	55	0.362 / 0.3145
.500 Plate	4.00	4" (100MM)	2.25	2.500	90	55	0.300 / 0.300
.625Plate	5.00	6" (150MM)	3.25	3.750	80	85	0.285 / 0.286
.750 Plate	6.00	6" (150MM)	3.25	3.750	80	85	0.265 / 0.265
1.00 Plate	8.00	6" (150MM)	3.50	4.00	80	85	0.235 / 0.235



86° (90°) dies available

Size	Length
0.3149" (8mm)	42
0.472" (12mm)	42
5/8" (16mm)	42
1.5" (40mm)	159

5052 AL K factors

Thickness	K factor
0.0478	0.135
0.063	0.5
0.08	0.41
0.1	0.485
0.125	0.5
0.188	0.415
0.25	0.345
0.313	0.328
0.375	0.3135

Radius punches available

Size	Length
0.04 R (1mm)	159
0.16 R (4mm)	159
0.375 R	78.75
0.500 R	98.50
0.750 R	78.75
1.000 R	98.50
1.500 R	78.75

Trumpf TruBend 7036 / 5320

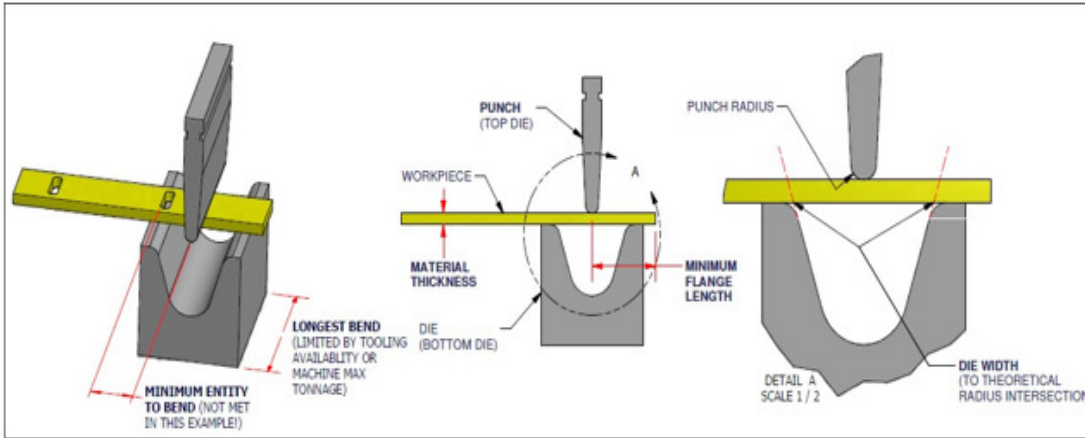

All dimensions measured to inside of bends

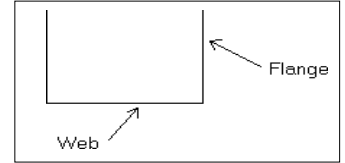

Maximum Flange Lengths typical for all material thicknesses.

Extreme

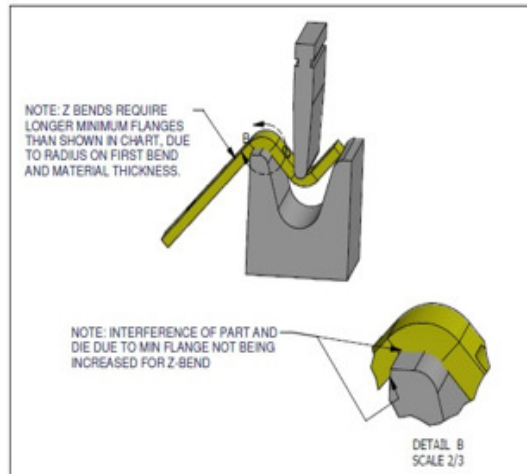
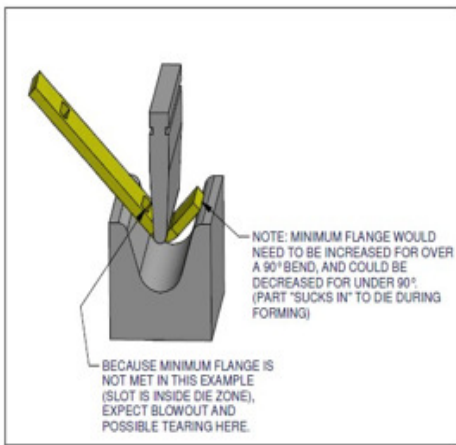

Web	Max Flange
0.75	1.25
1	2
2	3.25
3	4.25
4	5.25
4.5	5.25
5	5.25
5.5	5.13
6	5
6.5	5
7	5.5
7.5	5.5
8	6
10	7.25
12	9.25
15	12.2
18	15.2
21	18.2
24	21.2
30	27.2
36	33.2

MAX FLANGE HEIGHT FOR <10" WEB

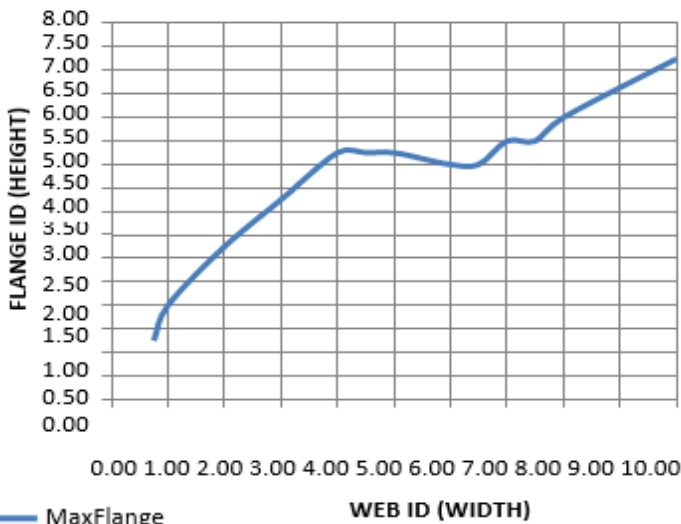

Forming Tolerance	
Thickness	+/-
18 ga - 10ga	1/32
3/16 - 1/2	1/16
5/8 +	3/32
Angular = +/- 1 deg.	

MAX FLANGE HEIGHT FOR >10" WEB

FLANGE = WEB-2.8



GK MACHINE, INC. DONALD, OREGON

503-678-5525

www.Gkmachine.com